

Weder die noch Herstellung dieses Dokuments, Vervielfältigung und Mitteilung seines Inhaltes, sind  
 verboten, soweit nicht ausdrücklich gestattet. Zuwidergehungen verpflichten zu Schadenersatz. Alle  
 Rechte für den Fall der Patent-, Gebrauchsmuster- oder Geschmacksunterzeichnung vorbehalten.  
 "Schutzvermerk nach DIN ISO 16016 beachten" Technische Änderungen vorbehalten!

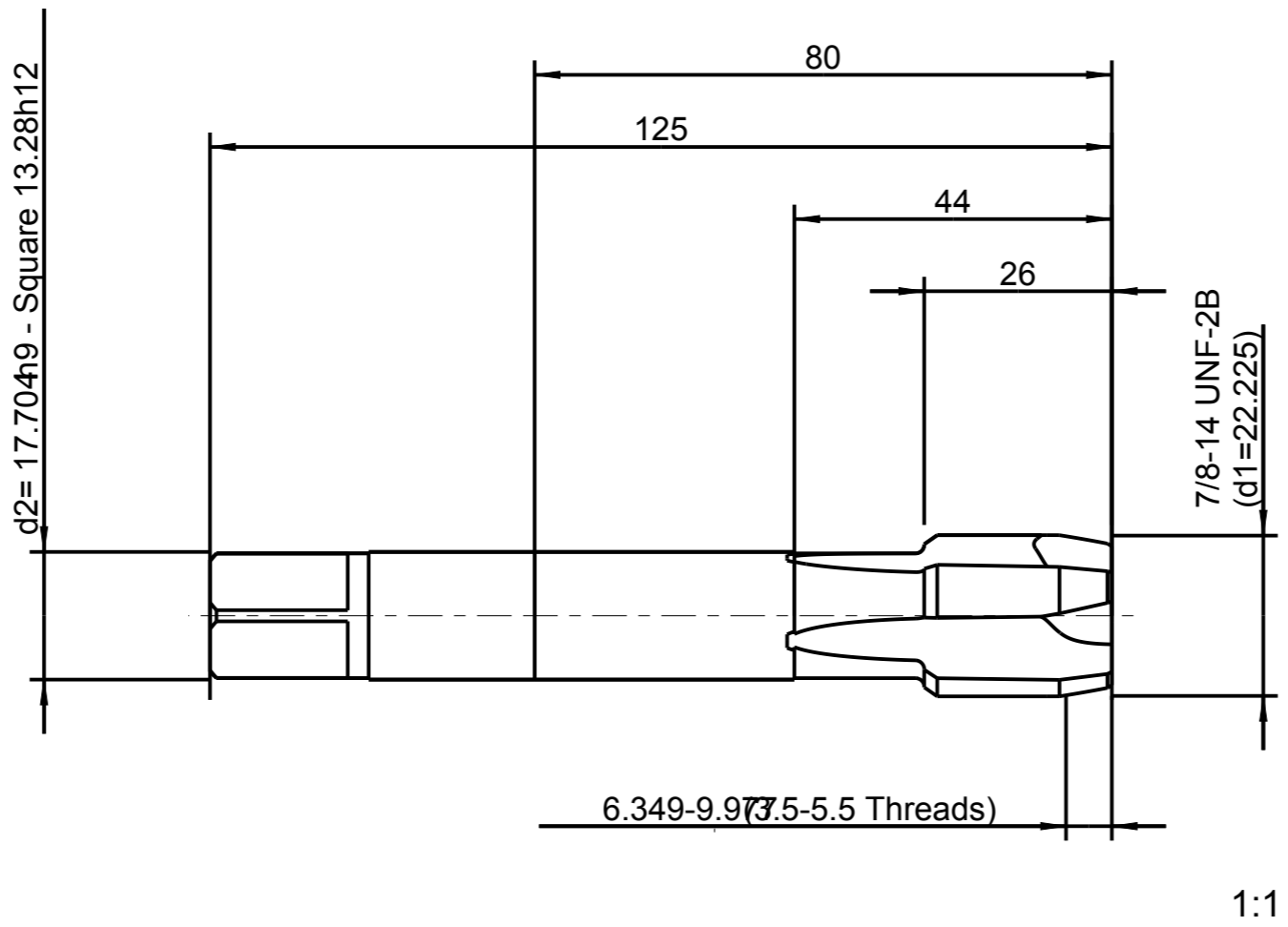

Issued with CAD! Changes to be made only on the CAD/CAM modell

The reproduction, distribution and utilization of this document as well as the  
 communication of its contents to others without explicit authorization is  
 prohibited. Any use of the information contained herein without the written  
 consent of the copyright holder is prohibited. All rights reserved. In the event of the grant of a patent, utility model or design,  
 "Observe protective mark according to DIN ISO 16016" Technical data is subject to change without notice!



Identification

EMUGE-STEEL Rekord 2B-STEEL-L-TIN 7/8-14 UNF-2B  
 Kom.-Nr.

 EMUGE-Werk Richard Glimpel GmbH & Co. KG www.emuge-franken.com		Document Type		Documentary drawing																			
		Description				US-Rek.2B-STEEL-L-TIN 7/8-14 UNF-2B																	
General tolerances ISO 2768-mk		Sheet	View	Customer																			
<table border="1"> <tr> <td>&gt;</td> <td>6</td> <td>30</td> <td>120</td> <td>400</td> <td>1000</td> </tr> <tr> <td>≤</td> <td>6</td> <td>30</td> <td>120</td> <td>400</td> <td>2000</td> </tr> <tr> <td></td> <td>±0,1</td> <td>±0,2</td> <td>±0,3</td> <td>±0,5</td> <td>±0,8 ±1,2</td> </tr> </table>		>	6	30	120	400	1000	≤	6	30	120	400	2000		±0,1	±0,2	±0,3	±0,5	±0,8 ±1,2	1/1		Component	
>	6	30	120	400	1000																		
≤	6	30	120	400	2000																		
	±0,1	±0,2	±0,3	±0,5	±0,8 ±1,2																		
Issued by		Date of issue	Replaced by	Material no.																			
CAD/TF		18.05.2018		Order no. CU208400.5051																			
Checked by		Date	Replacement for	Customer drawing no.																			
				Drawing no. CU208400.5051																			

A3